

FREE SHIPPING ON ALL SPECIAL ORDERS AND OUT OF STOCK ITEMS.

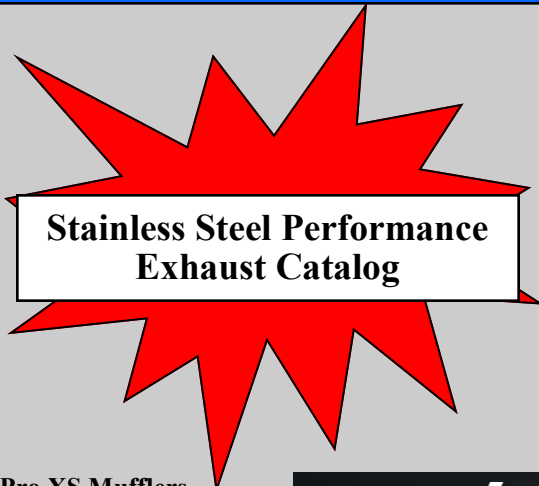

Stainless Steel Performance Exhaust Catalog



High Performance Stainless Steel Muffler 4in. Round

- In/Out: 2.5"
- Length: 14"
- Overall: 20"
- Config.: Center Center
- Part#: XS0416



Pro XS Mufflers

- C/D
- Oval
- 3"/2.25" In/Out
- 19"x4"x9.5" Case
- 24" OAL
- Notch: No
- Part#: 40670



MAX Stainless Steel Reversible Mufflers

- In/Out 2 1/4"
- Config. O/C
- Body 14"
- OAL 20"
- Part#: M11225



Performance Products

Stainless Steel OE Whisper Quiet Direct Fit Mufflers

- O/O
- 1 5/8" In
- 1 3/4" Out
- 14" Body Length
- 24" Overall
- Part#: OE71S



Stainless Steel Tips

- Hi Polished Stainless Steel Tips
- 4" Round
- 9" Long
- 2 1/4" Inlet
- Part#: 00731



HENSCHEL & SONS

EXHAUST WAREHOUSE
724-628-6915
CONNELLSVILLE, PA

1502 Memorial Blvd
Connellsville, PA 15425
724-628-6915 Fax 724-628-6934
Web: www.henschelandsons.com
www.facebook.com/henschelandsons

ORDER ONLINE: www.henschelandsons.com

CATALOG INDEX

• Aero Exhaust Mufflers-----3	• Flo-Pro Exhaust Tips-----16
• AP Exhaust Performance Mufflers---4	• Flowmaster Mufflers and Exhaust Systems-----17
• AP Exhaust Universal Converters---5-6	• Magnaflow Performance Exhaust Systems-----18
• AP Exhaust Direct-Fit Converters---7	• Magnaflow Performance Mufflers---19
• AP Exhaust DieselTech Clamps and Flex Tubing-----8	• Magnaflow Exhaust Tips and Transition Pipes-----20
• AP Exhaust Tips-----9	• Magnaflow Universal Converters---21
• Borla Exhaust Mufflers, Clamps, and Tubing-----10	• Magnaflow Direct-Fit Converters---22
• Cherry Bomb Exhaust Mufflers---11	• Mandrel Prebent Pipes and Stainless Tubing-----23
• Different Trend Exhaust Mufflers, Tips, and Flex Pipes-----12	• Flex Pipes, Nickson, and Pollution Control Exhaust Accessories-----24
• Flo-Pro Performance Exhaust Systems-----13	• Performance Products Mufflers and Mandrel Bends-----25
• Flo-Pro Exhaust Pipes, Mufflers, and Glasspacks-----14	• Thunderbolt Exhaust Tips and Mufflers with Tips-----26-27
• Flo-Pro Exhaust Y&X Pipes, and Mufflers with tips-----15	• Thunderbolt Spun Formed Converters-----28

**HENSCHEL
& SONS**



EXHAUST WAREHOUSE

724-628-6915
CONNELLSVILLE, PA

FREE SHIPPING ON ALL SPECIAL ORDERS AND OUT OF STOCK ITEMS.



Now
Carries:



**304
Stainless
Steel**

Another Great Brand Added to our Line Card!

AERO Exhaust offers a premium line of high-quality performance mufflers, resonators, and direct-fit kits. All fully constructed from 304 grade stainless steel and backed by a lifetime limited warranty. Become part of an exclusive network of authorized dealers. **Most importantly this brand is 100% MAP enforced, protecting your investment!**



TURBINE

Aggressive Sound



- Patented Airfoil Cone Technology
- 100% 304 Stainless Steel
- Hand Polished Mirror Finish
- Fully Welded Construction
- Increased Power & Torque
- Lifetime Limited Warranty

Part#	Body Length	Overall Length	Body Diam.	Inlet	Outlet
AT2525	14"	20"	6"	2.5"	2.5"
AT3030	14"	20"	6"	3"	3"
AT30401	14"	20"	6"	3"	4" Rolled Tip
AT3535	14"	20"	6"	3.5"	3.5"
AT4040	14"	20"	6"	4"	4"
AT5050	14"	20"	7"	5"	5"

AR Series RESONATOR

Hand Polished 304 Stainless Steel



- Reduces Interior Drone
- 100% 304 Stainless Steel
- High Temp Ceramic Material
- Straight Through Performance Design
- Hand Polished Mirror Finish
- Lifetime Limited Warranty

Part#	Body Length	Overall Length	Body Diam.	Inlet	Outlet
AR30	10"	14"	6"	3"	3"
AR50	16"	20"	7"	5"	5"

TURBINE XL

Moderate Sound



- Built-in Tuned Resonator
- 100% 304 Stainless Steel
- Hand Polished Mirror Finish
- Fully Welded Construction
- Increased Power & Torque
- Lifetime Limited Warranty

Part#	Body Length	Overall Length	Body Diam.	Inlet	Outlet
AT2525XL	20"	26"	6"	2.5"	2.5"
AT3030XL	20"	26"	6"	3"	3"
AT3040XL	20"	26"	6"	3"	4"
AT3535XL	20"	26"	6"	3.5"	3.5"
AT4040XL	20"	26"	6"	4"	4"
AT5050XL	26"	30"	7"	5"	5"

TR Series RESONATOR

Satin Finish 304 Stainless Steel

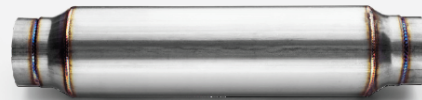

- Reduces Interior Drone
- 100% 304 Stainless Steel
- High Temp Ceramic Material
- Straight Through Performance Design
- Raw Satin Finish
- Lifetime Limited Warranty

Part#	Body Length	Overall Length	Body Diam.	Inlet	Outlet
TR20	7"	8"	3.5"	2"	2"
TR225	6"	8"	4.5"	2.25"	2.25"
TR251	9.5"	10.5"	3.5"	2.5"	2.5"
TR252	12.5"	13.5"	3.5"	2.5"	2.5"
TR253	14.5"	15.5"	3.5"	2.5"	2.5"
TR254	5"	6.5"	4"	2.5"	2.5"
TR31	13"	16"	5"	3"	3"
TR32	14"	16"	4"	3"	3"
TR33	11"	14"	4"	3"	3"

Ask your salesperson for further details.

Phone: (724) 628-6915

Web: henschelandsons.com

Fax: (724) 628-6934

ORDER ONLINE: www.henschelandsons.com

HIGH PERFORMANCE STAINLESS STEEL MUFFLERS

- Heavy gauge 100% 409 Stainless Steel
 - All Welded Construction
 - Straight Through Flow Design
 - Increase Flow
 - Excellent Performance Sound
 - Reversible
- High Temperature Acoustical Filler Material



4in. Round

In/Out	Length	Overall	Config.	Part #
2.5"	14"	20"	Center/Center	XS0416
2.25"	18"	24"	Center/Center	XS0425
2.5"	18"	24"	Center/Center	XS0426
3"	14"	20"	Center/Center	XS0433
2.25"	14"	20"	Center/Center	XS0445

4" x 9" Oval

In/Out	Length	Overall	Config.	Part #
2.25"	14"	20"	Center/Dual	XS1149
2.25	14"	20"	Offset/Center	XS1225
2.5	14"	20"	Offset/Center	XS1226
2.5	14"	20"	Offset/Offset	XS1236
2.25	18"	24"	Offset/Center	XS1255
2.5	18"	24"	Offset/Center	XS1256
3	18"	24"	Offset/Center	XS1259
2.5	18"	24"	Offset/Offset	XS1266
2.5/ 2.25	14"	20"	Center/Dual	XS2157

4" x 9" Oval

In/Out	Length	Overall	Config.	Part #
3/2.25"	14"	20"	Center/Dual	XS2197
3/2.5	14"	20"	Center/Dual	XS2198
2.5/ 2.25	18"	24"	Center/Dual	XS2258
2.5	18"	24"	Transverse &Offset/Dual	XS2265
3/2.25	18"	24"	Center/Dual	XS2278
3/2.5	18"	24"	Center/Dual	XS2288
3	18"	24"	Center/Dual	XS2298

5" x 11" Large Oval

In/Out	Length	Overall	Config.	Part #
2.5	22"	28"	Dual/Dual	XS2568
3	22"	28"	Center/Center	XS2579
2.5/3 3/2.5	22"	28"	Dual/Center Center/Dual	XS2588
3	22"	28"	Center/Offset	XS2589

7" Round

In/Out	Length	Overall	Config.	Part #
5"	24"	30"	Center/Center	XS2774

FREE SHIPPING ON ALL SPECIAL ORDERS AND OUT OF STOCK ITEMS.



UNIVERSAL CONVERTERS



409 Stainless Steel Bodies

6020**/6022** Series Standard Duty

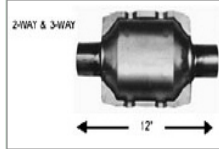

P/N	IN	OUT	OAL	CONFIGURATION
602004	2"	2"	14"	w/Air Tube
602005	2 1/4"	2 1/4"	14"	w/Air Tube
602006	2 1/2"	2 1/2"	14"	w/Air Tube
602007	3"	3"	14"	w/Air Tube

6060** Series Super Duty



P/N	IN	OUT	OAL	CONFIGURATION
606007	3"	3"	21 1/2"	Oval w/o Air Tube

608*** Series

EPA OBDII By Design

OBDII Vehicles up to LEV

602*** Specialty Standard Duty

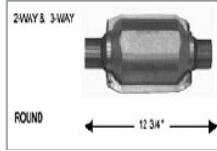

P/N	IN	OUT	OAL	CONFIGURATION
602213	1 3/4"	1 3/4"	12 3/4"	Round w/o Air Tube
602214	2"	2"	12 3/4"	Round w/o Air Tube
602215	2 1/4"	2 1/4"	13"	Round w/o Air Tube
602216	2 1/2"	2 1/2"	13"	Round w/o Air Tube

6025** Series

Enhanced Standard Duty

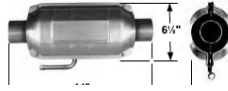

P/N	IN	OUT	OAL	CONFIGURATION
602543	1 3/4"	1 3/4"	16"	Oval w/o Air Tube
602544	2"	2"	16"	Oval w/o Air Tube
602545	2 1/4"	2 1/4"	16"	Oval w/o Air Tube
602546	2 1/2"	2 1/2"	16"	Oval w/o Air Tube
602547	3"	3"	16"	Oval w/o Air Tube

6040** Series

Heavy Duty

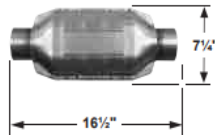

P/N	IN	OUT	OAL	CONFIGURATION
604007	3"	3"	16 1/2"	Oval w/o Air Tube

6050** Series Heavy Duty

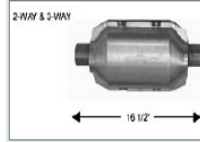

P/N	IN	OUT	OAL	CONFIGURATION
605007	3"	3"	17"	w/Air Tube

P/N	IN	OUT	OAL	CONFIGURATION
608204	2"	2"	16"	Oval w/o Air Tube
608205	2 1/4"	2 1/4"	16"	Oval w/o Air Tube
608206	2 1/2"	2 1/2"	16"	Oval w/o Air Tube
608214	2"	2"	16"	Round w/o Air Tube
608215	2 1/4"	2 1/4"	16"	Round w/o Air Tube
608216	2 1/2"	2 1/2"	16"	Round w/o Air Tube
608217	3"	3"	16"	Round w/o Air Tube
608224	2"	2"	16 1/2"	Oval w/o Air Tube
608225	2 1/4"	2 1/4"	16 1/2"	Oval w/o Air Tube
608226	2 1/2"	2 1/2"	16 1/2"	Oval w/o Air Tube
608227	3"	3"	16 1/2"	Oval w/o Air Tube
608234	2"	2"	16 1/2"	Oval w/o Air Tube w/2 O2 Sensor ports
608235	2 1/4"	2 1/4"	16 1/2"	Oval w/o Air Tube w/2 O2 Sensor ports
608240	2 1/2" Dual	2 1/2"	17"	w/O2 Port
608255	2 1/4"	2 1/4"	14"	Round w/O2 Port Mid. Body Position
608294	2"	2"	12"	w/O2 Port
608295	2 1/4"	2 1/4"	12"	w/O2 Port

EPA UNIVERSAL CONVERTER

STUFFED TUBE, NO NECKS

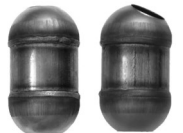

P/N	Body	OAL	In/Out	Config.
608364	4" Round	7"	2"	Straight
608365	4" Round	7"	2 1/4"	Straight
608366	4" Round	7"	2 1/2"	Straight
608374	4" Round	7"	2"	Angled/Straight
608375	4" Round	7"	2 1/4"	Angled/Straight

FREE SHIPPING ON ALL SPECIAL ORDERS AND OUT OF STOCK ITEMS.



UNIVERSAL CONVERTERS



409 Stainless Steel Bodies

608* Series**

SELECT+PLUS TECHSERIES

EPA OBDII By Design

ULEV AND CLEANER APPLICATIONS

LEVII and Cleaner Applications



P/N	IN	OUT	OAL	CONFIGURATION
608264	2"	2"	14"	Round w/o Air Tube
608265	2 1/4"	2 1/4"	14"	Round w/o Air Tube
608266	2 1/2"	2 1/2"	14"	Round w/o Air Tube
608274	2"	2"	12"	Angled Inlet and Outlet w/o Air Tube
608275	2 1/4"	2 1/4"	12"	Angled Inlet and Outlet w/o Air Tube
608276	2 1/2"	2 1/2"	12"	Angled Inlet and Outlet w/o Air Tube
608284	2"	2"	12 1/2"	Angled Inlet, w/o Air Tube
608285	2 1/4"	2 1/4"	12 1/2"	Angled Inlet, w/o Air Tube
608286	2 1/2"	2 1/2"	12 1/2"	Angled Inlet, w/o Air Tube
608316	2 1/2"	2 1/2"	16"	Round w/Air Tube
608326	2 1/2"	2 1/2"	16"	Two O2 Sensor Ports One In Middle Of Shell & One At Left Top Inlet
608314	2"	2"	16"	One O2 Sensor Port In Top Middle Of Body
608315	2 1/4"	2 1/4"	16"	One O2 Sensor Port In Top Middle Of Body
608404	2"	2"	14"	Oval w/o Air Tube
608405	2 1/4"	2 1/4"	14"	Oval w/o Air Tube
608406	2 1/2"	2 1/2"	14"	Oval w/o Air Tube
608407	3"	3"	14"	Oval w/o Air Tube
608414	2"	2"	12 1/4"	Round w/o Air Tube
608415	2 1/4"	2 1/4"	12 1/4"	Round w/o Air Tube
608416	2 1/2"	2 1/2"	12 1/4"	Round w/o Air Tube
608417	3"	3"	12 1/4"	Round w/o Air Tube
608435	2 1/4"	2 1/4"	16 1/2"	Oval w/o Air Tube
608437	3"	3"	16 1/2"	Oval w/o Air Tube

P/N	IN	OUT	OA L	CONFIGURATION
608704	2"	2"	14"	4" Round
608705	2 1/4"	2 1/4"	14"	4" Round
608706	2 1/2"	2 1/2"	14"	4" Round
608714	2"	2"	14"	4" Round w/O2 Port near outlet
608715	2 1/4"	2 1/4"	14"	4" Round w/O2 Port near outlet
608716	2 1/2"	2 1/2"	14"	4" Round w/O2 Port near outlet
608734	2"	2"	16"	4" Round
608735	2 1/4"	2 1/4"	16"	4" Round
608736	2 1/2"	2 1/2"	16"	4" Round
608737	3"	3"	16"	4" Round
608744	2"	2"	16"	4" Round w/Midbed O2 Port
608745	2 1/4"	2 1/4"	16"	4" Round w/Midbed O2 Port
608746	2 1/2"	2 1/2"	16"	4" Round w/Midbed O2 Port
608747	3"	3"	16"	4" Round w/Midbed O2 Port
608754	2"	2"	16"	4" Round w/End O2 Port
608755	2 1/4"	2 1/4"	16"	4" Round w/End O2 Port
608756	2 1/2"	2 1/2"	16"	4" Round w/End O2 Port
608757	3"	3"	16"	4" Round w/End O2 Port

Oval Universal, Pre OBDII

SUPER SELECT+ TECH SERIES



Features a new advanced washcoat and enhanced metal loading that improves the efficiency and durability of the catalyst.

Heavy Duty Specialty

P/N	IN	OUT	OAL	CONFIGURATION
609005	2 1/4"	2 1/4"	16 1/2"	w/Air Tube
609006	2 1/2"	2 1/2"	16 1/2"	w/Air Tube
609007	3"	3"	16 1/2"	Oval w/o Air Tube
609244	2" Dual	2 1/2"	17"	w/O2 Port

P/N	IN	OUT	OA L	CONFIGURATION
608894	2"	2"	15"	5" Round Two O2 Ports
608895	2 1/4"	2 1/4"	15"	5" Round Two O2 Ports
608896	2 1/2"	2 1/2"	15"	5" Round Two O2 Ports
608897	3"	3"	15"	5" Round Two O2 Ports

CARB Compliant

OBDII



**Spun Body
Converters**

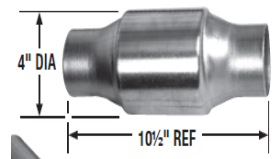

P/N	IN	OUT	OAL	CONFIGURATION
755006	2 1/2"	2 1/2"	13"	Round No O2 Port
912004	2"	2"	16 1/2"	Large Oval No O2 Port
912004R	2"	2"	16"	Round No O2 Port
912005	2 1/4"	2 1/4"	16 1/2"	Large Oval No O2 Port
912005R	2 1/4"	2 1/4"	16"	Round No O2 Port
912006	2 1/2"	2 1/2"	16 1/2"	Large Oval No O2 Port
912006R	2 1/2"	2 1/2"	16"	Round No O2 Port
912007	3"	3"	16 1/2"	Large Oval No O2 Port

Pre-OBD II Universal	Part Number
2"	602384
2 1/4"	602385
2 1/2"	602386
3"	602387

OBD II Universal	Part Number
2"	608384
2 1/4"	608385
2 1/4" w/O2 Sensor Fitting	608395
2 1/2" w/O2 Sensor Fitting	608396
3"	608387
3" w/O2 Sensor Fitting	608397

CARB Compliant Pre-OBDII

P/N	IN	OUT	OAL	CONFIGURATION
98104	2"	2"	14"	Round No O2 Port

ORDER ONLINE: www.henschelandsons.com

FREE SHIPPING ON ALL SPECIAL ORDERS AND OUT OF STOCK ITEMS.











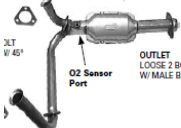













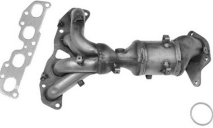
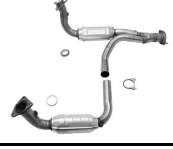









DIRECT-FIT CONVERTERS



409 Stainless Steel Bodies

MANY MORE AVAILABLE

 <p>645342 94 Chevy Blazer, 94-95 C&K Series Pick Up, 94-95 Suburban/Tahoe, 94-95 GMC C&K Series Pick Up,</p>	 <p>644015 10-15 Chevy Equinox, 10-15 GMC Terrain 2.4L</p>	 <p>642278 05-07 Buick Allure, 05-09 Lacrosse, 04-08 Pontiac Grand Prix</p>
 <p>642780 05-07 Chevrolet Cobalt 2.2L, HHR, 05-07 Saturn Ion 2.2L</p>	 <p>642165 03-08 Pontiac Vibe, 03-08 Toyota Corolla, Matrix</p>	 <p>641358 01-07 Ford Escape, 01-06 Mazda Tribute, 05-07 Mercury Mariner</p>
 <p>645269 07-09 Jeep Wrangler 3.8L</p>	 <p>642288 02-06 Honda CR-V</p>	 <p>642198 04-08 Chevy Malibu, 06-07 Pontiac G6, 07-09 Saturn Aura</p>
 <p>643032 08-10 Chrysler Town & Country, 08-10 Dodge Grand Caravan, 09-10</p>	 <p>642291 03 Subaru Baja, 99-05 Forester, 99-05 Impreza, 01-03 Legacy, 01-03 Outback</p>	 <p>641356 03-09 Acura MDX, 04-08 TL, 03-07 Honda Accord, 05-10 Odyssey, 05-08 Pilot, 06-08 Ridgeline,</p>
 <p>644035 08-17 Buick Enclave, 09-17 Chevy Traverse, 07-17 GMC Acadia, 07-10 Saturn</p>	 <p>644034 08-17 Buick Enclave, 09-17 Chevy Traverse, 07-17 GMC Acadia, 07-10 Saturn Outlook 3.6L</p>	 <p>641302 07-12 Nissan Altima 2.5L</p>
 <p>645236 02-05 Cadillac Escalade, 02-05 Chevy Avalanche, 00-06 Silverado, 00-05 Suburban, 00-05 Tahoe, 00-06</p>	 <p>642803 06 Saab 9-2X, 06-10 Subaru Forester, 06-11 Impreza, 06-12 Legacy, 06-12 Outback 2.5L</p>	 <p>643090 07-18 Nissan Altima 2.5L</p>
 <p>642033 09-19 Nissan Murano 3.5L</p>	 <p>644075 13-18 Buick Encore, 11-16 Chevy Cruze, 12-16 Sonic, 15-18 Trax 1.4L</p>	 <p>643001 02-11 Toyota Camry, 02-08 Solara 2.4L</p>
 <p>641384 11-14 Chrysler 200, 11-16 Town & Country, 11-14 Dodge Avenger, 11-19 Grand Caravan, 11-19 Journey, 12-15 Ram C/V, 11-14</p>	 <p>641530 07-08 Dodge Caliber, 07-17 Jeep Compass, 07-17 Patriot 2.0L, 2.4L</p>	 <p>644090 05-19 Nissan Frontier, 12-17 NV1500, NV2500, NV3500, 05-12 Pathfinder, 05-15 Xterra, 09-12 Suzuki Equator</p>
 <p>642245 03-07 Nissan Murano 3.5L</p>	 <p>642979 05-07 Chrysler Town & Country, 05-07 Dodge Caravan 3.3L, 3.8L</p>	 <p>641559 16-17 Subaru Crosstrek, 11-16 Forester, 12-16 Impreza, 13-14 Legacy, Outback, 13-15 XV</p>
 <p>645459 09 Cadillac Escalade, 07-08 Chevy Avalanche, Silverado 1500, Suburban 1500, 07-09 Tahoe, 07-10</p>	 <p>641353 04-10 Infiniti QX56, 05-15 Nissan Armada, 12-16 NV2500, NV3500, 08-12 Pathfinder, 04 Pathfinder</p>	 <p>641383 11-14 Chrysler 200, 11-16 Town & Country, 11-14 Dodge Avenger, 11-19 Grand Caravan, 11-19 Journey, 12-15 Ram C/V, 11-14 Volkswagen</p>
 <p>645328 00-99 Cadillac Escalade, 96-99 Chevy C1500, C2500, K1500, K2500, 96-00 Tahoe,</p>	 <p>644091 05-19 Nissan Frontier, 12-17 NV1500, NV2500, NV3500, 05-12 Pathfinder, 05-15 Xterra, 09-12 Suzuki Equator 4.0L</p>	



H.D. FLEET EXHAUST

EASY SEAL™ BRIGHT 304 STAINLESS STEEL CLAMPS



P/N	OD Size
B200	2"
B214	2 1/4"
B212	2 1/2"
B234	2 3/4"
B300	3"
B312	3 1/2"
B400	4"
B500	5"

FLEX TUBING



P/N 409 Stainless Steel Standard Thickness	ID	Length
8887	4"	10'
8888	5"	10'

FLATBAND EXHAUST CLAMPS



P/N	Size	Material
SAS200	2"	Bright 304 Stainless Steel
SAS214	2 1/4"	Bright 304 Stainless Steel
SAS212	2 1/2"	Bright 304 Stainless Steel

PRE-CUT FLEX HOSE STYLE ID-ID



P/N 409 Stainless Steel	DIA	LGTH.
24836	4"	24"
24838	5"	24"

PREFORMED CLAMPS - LAP JOINT



P/N	Size	Material
9664	2"	304 Stainless Steel
9666	2 1/2"	304 Stainless Steel
9668	3"	304 Stainless Steel
9623	4"	304 Stainless Steel

409 Stainless Steel 3/8" U-Bolt



P/N	SIZE	BOX QTY
SS214	2 3/4"	1
SS212	2 1/2"	1
SS300	3"	1



409 STAINLESS EXHAUST TIPS



ANGLE CUT TIPS

Stainless P/N	Inlet Size	OAL x Outlet
<u>XSAC214</u>	2 1/4"	8" x 2 1/2"
<u>XSAC212</u>	2 1/2"	8" x 2 3/4"
<u>XSAC31218</u>	2 1/4"	18" x 3 1/2"
<u>XSAC412</u>	2 1/2"	12" x 3 1/2"



INSIDE ROLL ANGLE CUT TIPS

Stainless		
Stainless P / N	Inlet Size	OAL x Outlet
<u>XSRAC31212</u>	2 1/4"	12" x 3 1/2"
<u>XSRAC31218</u>	2 1/4"	18" x 3 1/2"



BOLT-ON / CLAMP-ON TIPS

Stainless		
Stainless P / N	Inlet Size	OAL x Outlet
<u>ST1253S</u>	2 1/4"	5 1/2" x 3"



INSIDE ROLL PENCIL TIPS

Stainless P / N	Inlet Size	OAL x Outlet
<u>XSRPT212</u>	2 1/2"	8" x 2 1/2"



SPECIALTY TIPS

Stainless		
Stainless P / N	Inlet Size	OAL x Outlet
<u>XSR600</u>	2 1/4"	9" x 3"



CHEVY BOWTIE TIPS

Stainless		
Stainless P / N	Inlet Size	OAL x Outlet
<u>XSCB214</u>	2 1/4"	9" x 4 3/4"
<u>XSCB212</u>	2 1/2"	9" x 4 3/4"



TOYOTA/LEXUS TIP

Stainless			
Stainless P / N	Inlet Size	Outlet	Length
<u>9850</u>	W/Mounting Saddle for 2" Pipe	2 3/4" x 3 7/16"	5 1/16"



Dual Pencil Tips

Stainless		
Stainless P / N	Inlet Size	OAL x Outlet
<u>XDP200</u>	2" ID	11" x 5 1/2" (outlet 2 1/4")



45°SLASH CUT ANGLE TIPS WITH NECK

Stainless			
Stainless P / N	Inlet Size	Outlet	Length
<u>TK3518S25</u>	2 1/2"	3 1/2"	18"

FREE SHIPPING ON ALL SPECIAL ORDERS AND OUT OF STOCK ITEMS.



T-304 Stainless Steel Products

ProXS Mufflers

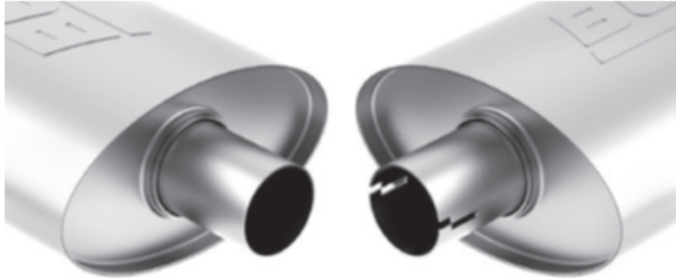

Un-Notched

Notched

Un-Notched mufflers recommended for welded installation

Notched mufflers recommended for clamped installation

Part#	Size
40670	C/D, Oval, 3"/2.25" In/Out, 19"x4"x9.5" Case, 24" OAL, Notch: No
400287	D/D, Oval, 2.25" In/Out, 19"x4"x9.5" Case, 24" OAL, Notch: No
400478	C/O, Oval, 2.25" In/Out, 14"x4"x9.5" Case, 19" OAL, Notch: Yes
400479	C/O, Oval, 2.25" In/Out, 14"x4.25"x7.88" Case, 19" OAL, Notch: Yes
400483	C/O, Oval, 2.25" In/Out, 19"x4"x9.5" Case, 24" OAL, Notch: Yes
400484	C/O, Oval, 2.5" In/Out, 19"x4"x9.5" Case, 24" OAL, Notch: Yes
400485	C/D, Oval, 2.5" In/Out, 19"x4"x9.5" Case, 24" OAL, Notch: Yes
400487	C/D, Oval, 3"/2.5" In/Out, 19"x4"x9.5" Case, 24" OAL, Notch: Yes
400489	O/O, Oval, 2.25" In/Out, 14"x4"x9.5" Case, 19" OAL, Notch: Yes
400495	C/C, Oval, 2.25" In/Out, 14"x4"x9.5" Case, 19" OAL, Notch: Yes
400496	C/C, Oval, 2.5" In/Out, 14"x4"x9.5" Case, 19" OAL, Notch: Yes

**T-304
STAINLESS
STEEL
ACCUSEAL
CLAMPS**



Part#	Size
18322	2.25"
18325	2.5"

**T-304
STAINLESS
STEEL
STRAIGHT
TUBING**



Part#	Size
30350	2.5" Dia, 5' Long

**STAINLESS
STEEL
EXHAUST
CLEANER &
POLISH**



Part#	Size
21461	8 Oz. Bottle

Cherry Bomb Exhaust



Cherry Bomb 409 Stainless Steel Salute Mufflers



Part#/Price	In/Out	Con.	BL	OAL	Part#	In/Out	Con.	BL	OAL
SA0425	2 1/4"	C/C	18"	24"	SA2157	2 1/2"/2 1/4"	C/D	14"	20"
SA0445	2 1/4"	C/C	14"	20"	SA2158	2 1/2"	C/D	14"	20"
SA1224	2"	O/C	14"	20"	SA2197	3"/2 1/4"	C/D	14"	20"
SA1225	2 1/4"	O/C	14"	20"	SA2198	3"/2 1/2"	C/D	14"	20"
SA1226	2 1/2"	O/C	14"	20"	SA2258	2 1/2"/2 1/4"	C/D	18"	24"
SA1229	3"	O/C	14"	20"	SA2265	2 1/2"	Transverse	18"	24"
SA1235	2 1/4"	O/O	14"	20"	SA2268	2 1/2"	C/D	18"	24"
SA1236	2 1/2"	O/O	14"	20"	SA2298	3"	C/D	18"	24"
SA1255	2 1/4"	O/C	18"	24"	SA2568	2 1/2"	D/D	22"	28"
SA1256	2 1/4"	O/C	18"	24"	SA2588	3"/2 1/2"	C/D	22"	28"
SA1259	3"	O/C	18"	24"	SA2589	3"	O/C	22"	28"
SA1266	2 1/2"	O/O	18"	24"	SA2772	4"	C/C	24"	30"



Different Trend, Inc.
Quality Driven Products

409 Stainless Steel Mufflers

**FLOW II
OFFSET/CENTER**



Part#	Size
49224	2.00" In, 2.00" Out, 14" B.L., 20" OAL
49225	2.25" In, 2.25" Out, 14" B.L., 20" OAL
49226	2.50" In, 2.50" Out, 14" B.L., 20" OAL
49229	3.00" In, 3.00" Out, 14" B.L., 20" OAL
49256	2.50" In, 2.50" Out, 18" B.L., 24" OAL
49259	3.00" In, 3.00" Out, 18" B.L., 24" OAL

**FLOW II
CENTER/OFFSET**



Part#	Size
49207	2.50" In, 2.50" Out, 18" B.L., 21" OAL

**FLOW II
OFFSET/DUAL**



Part#	Size
49306	2.50" In, 2.50" Out, 18" B.L., 24" OAL

**FLOW II
OFFSET/OFFSET**



Part#	Size
49307	2.50" In, 2.50" Out, 18" B.L., 21" OAL

**Hi-Polished 409 Stainless Steel
Exhaust Tips**

**SLANTED
DOUBLE WALL**



Part#	Size
DT013A	2.25" In, 3.00" Out, 8" Length
DT013B	2.25" In, 3.50" Out, 8" Length
DT013C	2.25" In, 4" Out, 8" Length

**DOUBLE WALL
ANGLE**



Part#	Size
DT25101	2.50" In, 4" Out, 5.25" Length
DT25124S	2.50" In, 4" Out, 6" Length

**DOUBLE WALL
SLANT**



Part#	Size
DT-25113E	2.50" In, 5" Out, 9" Length

**DUAL 3.50"
DOUBLE WALL
ANGLE**



Part#	Size
DT-25013BDL	2.50" In, 7.75"x3.50" Out, 9.5" Length

**DUAL SLANTED
ROLLED EDGE**



Part#	Size
DT-026B	2.25" In, 7.25" (3.5"x2) Out, 12.5" Length

**DUAL 3" DOUBLE
WALL ANGLE
PARALLEL**



Part#	Size
DT-25083	2.50" In, 6.25" (3"x2) Out, 9.5" Length

**DUAL 3.5" DOUBLE
WALL STAGGERED
ROLLED SLANT**



Part#	Size
DT24156L Driver Side	2.25" In, 7.25" (3.5"x2) Out, 9.5" Length
DT24156R Passenger Side	2.25" In, 7.25" (3.5"x2) Out, 9.5" Length

**FLEXIBLE PIPE 409 STAINLESS
STEEL DOUBLE BRAID**

**ALL STAINLESS STEEL ALL THE
WAY THROUGH.**



Part#	ID	BL
DTF1704B	1.75"	4"
DTF1706B	1.75"	6"
DTF1708B	1.75"	8"
DTF2004B	2"	4"
DTF2008B	2"	8"
DTF2404B	2.25"	4"
DTF2406B	2.25"	6"
DTF2408B	2.25"	8"
DTF2504B	2.50"	4"
DTF2508B	2.50"	8"



Part#	ID	BL	OL
DTF1704N	1.75"	4"	8"
DTF1706N	1.75"	6"	10"
DTF1708N	1.75"	8"	12"
DTF2004N	2"	4"	8"
DTF2006N	2"	6"	10"
DTF2008N	2"	8"	12"
DTF2404N	2.25"	4"	8"
DTF2406N	2.25"	6"	10"
DTF2408N	2.25"	8"	12"
DTF2504N	2.50"	4"	8"
DTF2506N	2.50"	6"	10"
DTF2508N	2.50"	8"	12"

**INTERLOCK FLEXIBLE PIPE
STAINLESS STEEL**

**ALL STAINLESS STEEL ALL THE
WAY THROUGH.**





Part#	ID	BL
DTF1704BI	1.75"	4"
DTF1706BI	1.75"	6"
DTF1708BI	1.75"	8"
DTF2004BI	2"	4"
DTF2006BI	2"	6"
DTF2008BI	2"	8"
DTF2404BI	2.25"	4"
DTF2406BI	2.25"	6"
DTF2408BI	2.25"	8"
DTF3008BI	3"	8"

FREE SHIPPING ON ALL SPECIAL ORDERS AND OUT OF STOCK ITEMS.

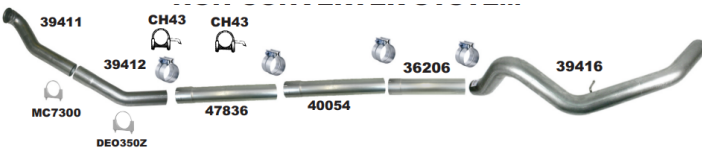
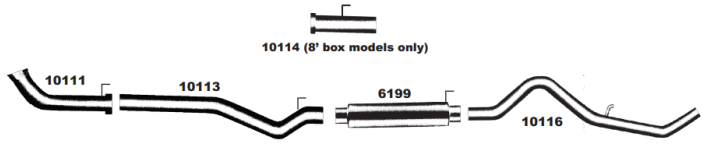

Most Popular Exhaust Kits!!! Many more available!!!

FORD KITS		DODGE KITS	
			
1994-1997.5, 7.3L, F250/350, Auto/Manual, Race Exhaust w/3" 2PC DP EC/SB-LB-Dually	409SS Kit#	1989-1993, 5.9L, 2500/3500, Race Exhaust, 4x4 Only, RC-EC/LB	409SS Kit#
4" Turbo-Back No Muffler Kit	SS821NM	4" Turbo-Back Single	SS847
1999-03, F250/350 Powerstroke, EC-CC, SB-LB 7.3L	409SS Kit#	1994-2002, 2500/3500 5.9L, RC-EC/SB-LB-Dually	409SS Kit#
4" Turbo Back Single System	SS831	4" Turbo-Back Single No Muffler Kit	SS802NM
4" Turbo-Back Single No Muffler Kit	SS831NM	2003-04 1/2, RAM 2500/3500 5.9L Turbo Back Systems, 2 & 4 WD, Pickup	409SS Kit#
2011-2014 Ford F-150 3.5L Ecoboost	409SS Kit#	4" Single With Hangers No Muffler	SS805NM
4" Cat-Back Single Tailpipe	SS865RS		
2015-2020 Ford F150 2.7L-3.5L-5.0L	409SS Kit#		
4" Cat-Back Single Tailpipe	SS881RS		
CHEV/GMC KITS		JEEP KITS	
			
2001-2007, 2500/3500 Duramax 6.6L Turbo Back System, 2 & 4 WD, Pickup	409SS Kit#	2012-2018 Jeep Wrangler JK	409SS Kit#
4" Single System	SS801	3" Cat-Back Exhaust	SS885
4" No Muffler Kit	SS801NM	2018-2019 Jeep Wrangler JL	409SS Kit#
5" Single System—4" Turbo Down Pipe	SS601	3" Cat-Back Exhaust	SS884
5" No Muffler Kit	SS601NM	2020 Jeep Gladiator JT	409SS Kit#
		3" Cat-Back Exhaust	SS886

FREE SHIPPING ON ALL SPECIAL ORDERS AND OUT OF STOCK ITEMS.

FLO~PRO

PERFORMANCE MUFFLERS

PIPES

DOWN PIPES



Part#	Application
39910	99-03 PS 7.3L SS
40111	01-07 GM 6.6L SS
59411	94-02 DG 5.9L SS

Polished 409 Stainless Steel Up-Pipes



Part#	Application
30400	2003-2007 6.0L Powerstroke F250/F350/F450/F550 Turbo Up Y-Pipe SS

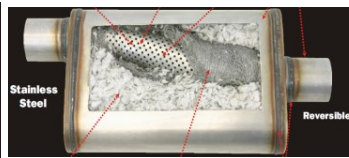

Heavy gauge stainless steel construction

Part #	In/Out	Config.	Body	OAL
M11225	2 1/4"	O/C	14"	20"
M11255	2 1/4"	O/C	18"	24"
M12158	2 1/2"	C/D	14"	20"
M12468	2 1/2"	D/D	18"	24"
M12568	2 1/2"	D/D	22"	28"
M11226	2 1/2"	O/C	14"	20"
M12258	2 1/2"/2 1/4"	C/D 5x8 Oval	18"	24"
M12298	3"	C/D	18"	24"
M12590	3"	C/D	22"	28"
M12469	3"	D/D	18"	24"
M11229	3"	O/C	14"	20"
M11259	3"	O/C 4x9 Oval	18"	24"
M12289	3"	O/C	24"	30"
M11239	3"	O/O	14"	20"
M12278	3"/2 1/4"	C/D	18"	24"
M12198	3"/2 1/2"	C/D	14"	20"
M12288	3"/2 1/2"	C/D	18"	24"



Part #	In/Out	Config.	Body	OAL
71299	4" Stainless	C/C	12"	18"
71600	5" Stainless	C/C	12"	18"

DIESEL MUFFLERS

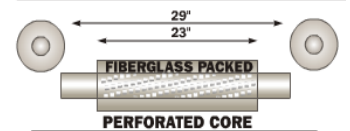

409 Stainless Steel

Inlet	Outlet	Part #
5"	5"	7196

Stainless Steel Resonators

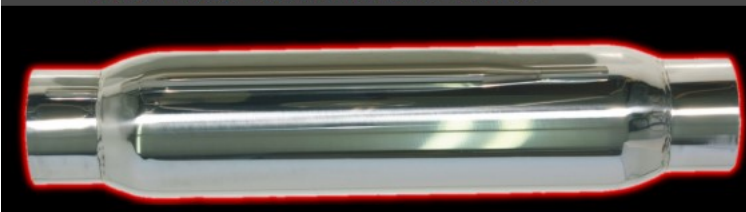

Case Diameter	Case Length	Core Diameter	Overall Length	End Sizes	End Position	Part #
3 1/2"	12"	2 1/4"	16"	2 1/4"	Straight	3512RS
3 1/2"	15"	2 1/4"	19"	2 1/4"	Straight	3515RS
4"	12"	2 1/2"	16"	2 1/2"	Straight	4512RS
4"	15"	2 1/2"	19"	2 1/2"	Straight	4515RS
4"	12"	3"	16"	3"	Straight	4312RS
4"	15"	3"	19"	3"	Straight	4315RS

ORDER ONLINE: www.henschelandsons.com

Now Available! FLO~PRO

Stainless

Y & X Pipes

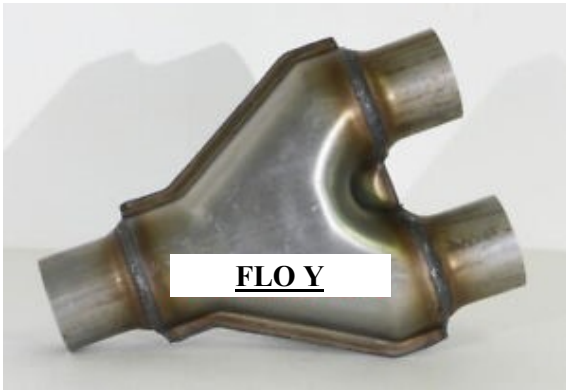

Single ID	Dual ID	Overall Length	409 Stainless Steel Part #
2"	2"	10"	SY200
2 ¼"	2 ¼"	10"	SY214
2 ½"	2 ½"	10"	SY212
3"	2 ¼"	10"	SY3214
3"	2 ½"	10"	SY3212
3"	3"	10"	SY300



End ID	Overall Length	409 Stainless Steel Part #
2 ¼"	12"	SX214
2 ½"	12"	SX212
3"	12"	SX300

409 Stainless Steel Mufflers



Part#	Inlet	Outlet	Body
SM106S	2-1/4"	4"	14"



Part#	Inlet	Outlet	Body
SM111	2-1/4"	4-1/2"	14"

FREE SHIPPING ON ALL SPECIAL ORDERS AND OUT OF STOCK ITEMS.

FLO~PRO PERFORMANCE EXHAUST

Stainless 304 Tips
Most Popular #s
Many More Available



**Rolled Angle Cut
Black Powder
Coated**

Part#	Inlet	Outlet	Length
4707RACK	2-1/4"	3-1/2"	7"
5718RACK	2-1/2"	3-1/2"	18"
5812RACK	2-1/2"	4"	12"
5818RACK	2-1/2"	4"	18"

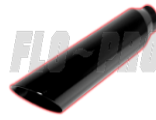

**45 Degree Angle
Black Powder
Coated**

Part#	Inlet	Outlet	Length
5818ACK	2-1/2"	4"	18"



**15 Deg Rolled Angle Cut
Black Chrome**

Part#	Inlet	Outlet	Length
254009RAC2	2-1/4"	4"	9"



**45 Deg Angle Cut
Clamp or Weld On**

Part#	Inlet	Outlet	Length
5718AC	2-1/2"	3-1/2"	18"

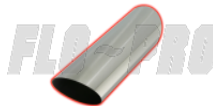

45 Deg Angle Cut

Part#	Inlet	Outlet	Length
243012AC	2-1/4"	3"	12"
243016AC	2-1/4"	3"	16"
243518AC	2-1/4"	3-1/2"	18"
254018AC	2-1/2"	4"	18"
254022AC	2-1/2"	4"	22"
304012AC	3"	4"	12"



Rolled Angle Cut

Part#	Inlet	Outlet	Length
243518RAC	2-1/4"	3-1/2"	18"
244012RAC	2-1/4"	4"	12"
253518RAC	2-1/2"	3-1/2"	18"
254009RAC	2-1/2"	4"	9"
254012RAC	2-1/2"	4"	12"
254018RAC	2-1/2"	4"	18"
304012RAC	3"	4"	12"

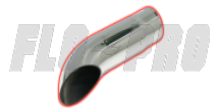

Turn Down

Part#	Inlet	Outlet	Length
4509TD	2-1/4"	2-1/2"	9"



**Rolled Angle Cut
Clamp or Weld On**

Part#	Inlet	Outlet	Length
5812RAC	2-1/2"	4"	12"
5818RAC	2 1/2"	4"	18"
406015RAC	4"	6"	15"



Rolled Oval Slant

Part#	Inlet	Outlet	Length
ST043S	2-1/4"	5-1/2"x3"	9"



Dual Oval Slant

Part#	Inlet	Outlet	Length
ST079	2-1/4"	3-1/2"x3"	9"

FREE SHIPPING ON ALL SPECIAL ORDERS AND OUT OF STOCK ITEMS.



Super 10
The most aggressive muffler



40 Series
The original high performance Flowmaster muffler



Super 40 Series
Deeper, richer tone than original 40 series muffler



40 Series Delta Flow
The quietest muffler option in the 40 series two-chambered line

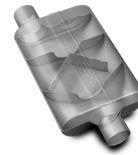

Super 44
Deep, aggressive, high performance exhaust note



Part#	In/Out	Con-fig.	Body Length	Material	Series
8042441	2 1/4"	O/C	13"	409 Stainless	40
8042443	2 1/4"	O/O	13"	409 Stainless	40
842515	2 1/2"	C/C	6 1/2"	409 Stainless	Super 10
842512	2 1/2"	C/O	6 1/2"	409 Stainless	Super 10
8425154	2 1/2"	D/D	6 1/2"	409 Stainless	Super 10
8525454	2 1/2"	D/D	13 1/2"	409 Stainless	Super 40
8042541	2 1/2"	O/C	13"	409 Stainless	40
842516	2 1/2"	O/C	6 1/2"	409 Stainless	Super 10
842518	2 1/2"	O/O	6 1/2"	409 Stainless	Super 10
8042543	2 1/2"	O/O	13"	409 Stainless	40
8425152	2 1/2"/2 1/4"	C/D	6 1/2"	409 Stainless	Super 10
843015	3"	C/C	6 1/2"	409 Stainless	Super 10
8043041	3"	O/C	13"	409 Stainless	40
843016	3"	O/C	6 1/2"	409 Stainless	Super 10
8043043	3"	O/O	13"	409 Stainless	40
8430152	3"/2 1/2"	C/D	6 1/2"	409 Stainless	Super 10
80430402	3"/2 1/2"	C/D	13"	409 Stainless	40

409 Stainless#	In/Out	Config.	Body Length	Series
842446	2 1/4"	O/C	13"	Super 44
842448	2 1/4"	O/O	13"	Super 44
842547	2 1/2"	C/O	13"	Super 44
8425454	2 1/2"	D/D	13"	Super 44
842546	2 1/2"	O/C	13"	Super 44
842543	2 1/2"	O/O	13"	40 Delta Flow
842548	2 1/2"	O/O	13"	Super 44
843041	3"	O/C	13"	40 Delta Flow
843046	3"	O/C	13"	Super 44
843048	3"	O/O	13"	Super 44
8430402	3"/2 1/2"	C/D	13"	40 Delta Flow
8430452	3"/2 1/2"	C/D	13"	Super 44

Super 50
The most versatile muffler they make for a wide variety of applications

50 Delta Flow
Moderate tone-perfect for performance and passenger cars



409 Stainless#	In/Out	Con-fig.	Body Length	Series
8524553	2 1/4"/3"	D/C	17"	Super 50
842551	2 1/2"	O/C	17"	50 Delta Flow
843051	3"	O/C	17"	50 Delta Flow
8430502	3"/2 1/2"	C/D	17"	50 Delta Flow

80 Crossflow
Aggressive sound and increased power/torque output over stock

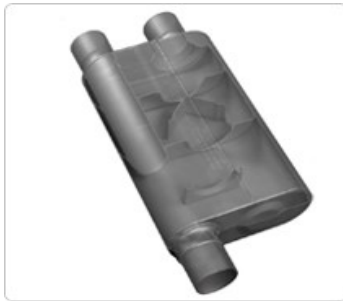

409 Stainless#	In/Out	Config.	Body Length	Series
842583	2 1/2"	O/D	15"	80 Crossflow

Part# **815425**
Outlaw Muffler, 409 Stainless, 2 1/2" Center In, 2 1/2" Center Out, Aggressive Sound, 11" Body Length

Part# **817717**
Outlaw Cat-Back Exhaust System 2015-2016 Dodge Challenger R/T with 5.7L Hemi engine



FlowFX Series
Moderate exterior performance tone, Flowmaster Quality, Durable fully welded 409S stainless steel case, Straight through design



Stainless#	In/Out	Config.	Body Length	OAL
4" x 9" Oval Body Mufflers				
71225	2 1/4"	O/C	14"	20"
71235	2 1/4"	O/O	14"	20"
71226	2 1/2"	O/C	14"	20"
71236	2 1/2"	O/O	14"	20"
71229	3"	O/C	14"	20"
72198	3"/2 1/2"	C/D	14"	20"
4" Round Body Mufflers				
71416	2 1/2"	C/C	14"	20"
71419	3"	C/C	14"	20"

FREE SHIPPING ON ALL SPECIAL ORDERS AND OUT OF STOCK ITEMS.

MAGNAFLOW

**POWER
AND SOUND**



Performance Exhaust Systems For
• Diesel & Gas Trucks • Sport Compacts
• American Muscle Cars

Whether you drive a street, off-road or diesel truck/SUV, MagnaFlow has dyno-proven exhaust systems that are rugged enough to survive grueling Baja racing. Each system is designed to bolt right on and provide years of trouble-free performance. Provides a smooth, deep tone that is suitable for grocery-getting SUV's with casual tow duties to full blown modded drag racing diesel pickups.

- Delivers a Smooth, Deep Tone
- Lifetime Warranty on All MagnaFlow Performance Kits
- Fully Polished Mufflers
- 100% 409 Stainless Steel

**MANY
MORE
AVAILABLE!!!**

CARS

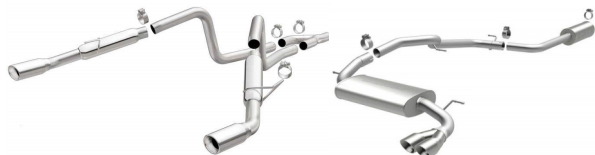

PART#	DESCRIPTION
15072	12-18 L4 2.0L; Ford Focus; 2.25in. Cat-Back; Single Straight Passenger Side Exit Style
15078	2010 V6 4.0L; Ford Mustang; 2.5in. Cat-Back; Quad Split Rear Exit Style
15090	10-13 V8 6.2L; Chevy Camaro; 2.5in. Cat-Back; Dual Split Rear Exit Style
15155	13-18 L4 2.0L; Ford Focus; 2.5in. Cat-Back; Dual Center Rear Exit Style
15160	07-18 V6 3.6L, 3.8L; Jeep Wrangler; 2.5in. Axle-Back; Dual Split Rear Exit Style; Black Coated Finish
15178	07-18 V6 3.6L, 3.8L; Jeep Wrangler; 2.5in. Axle-Back; Dual Split Rear Exit Style; Polished Finish
15244	2014 V6 3.7L; Ford Mustang; 2.5in. Cat-Back; Dual Split Rear Exit Style
16605	05-09 V6 4.0L; Ford Mustang; 2.5in. Cat-Back; Dual Split Rear Exit Style
16710	75-79 V8 5.7L; Chevy Corvette; 2.5in. Cat-Back; Dual Split Rear Exit Style
19367	15-21 V8 5.7L, 6.2L, 6.4L; Dodge Challenger; 3in. Cat-Back; Quad Split Rear Exit Style

TRUCKS

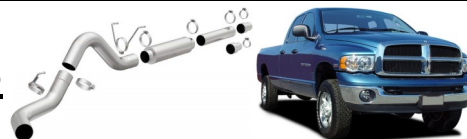

PART#	DESCRIPTION
15268	14-19 V6, V8 4.3L, 5.3L; Chevy/GMC Silverado/Sierra 1500; 3in. Cat-Back; Single Dual Split Rear Exit Style
17876	03-07 L6 5.9L Diesel; Dodge Ram 2500/3500; 5in. Cat-Back; Single Passenger Side Rear Exit Style
17879	99-03 V8 7.3L Diesel; Ford F-250/F-350 Super Duty; 5in. Turbo-Back; Single Passenger Side Rear Exit Style
17878	99-03 V8 7.3L Diesel; Ford F-250/F-350 Super Duty; 4in. Turbo-Back; Single Passenger Side Rear Exit Style
17880	01-04 V8 6.6L Diesel; Chevy/GMC Silverado/Sierra 2500/3500; 4in. Downpipe-Back; Single Passenger Side Rear Exit Style
17881	01-04 V8 6.6L Diesel; Chevy/GMC Silverado/Sierra 2500/3500; 5in. Downpipe-Back; Single Passenger Side Rear Exit Style
17882	99-02 L6 5.9L Diesel; Dodge Ram 2500/3500; 4in. Turbo-Back; Single Passenger Side Rear Exit Style
18942	14-19 V8 6.6L Diesel; Chevy/GMC Silverado/Sierra 2500/3500; 4in. Filter-Back; Dual Same Side Behind Passenger Rear Tire Exit Style
18943	07-19 V8 6.6L Diesel; Chevy/GMC Silverado/Sierra 2500/3500; 4in. Filter-Back; Single Passenger Side Rear Exit Style
18952	99-03 V8 7.3L Diesel; Ford F-250/F-350 Super Duty; 4in. Turbo-Back; Dual Split Rear Behind Rear Tires Exit Style

ORDER ONLINE: www.henschelandsons.com

MAGNAFLOW

MANY
MORE
AVAILABLE!!!

STAINLESS STEEL MUFFLERS

**5"x8" Oval 409 Satin Stainless
Straight Through Performance
Muffler**



Part#	Config.	In/Out	Body Length	Overall
12158	C/D	2.5"	14"	20"
12198	C/D	3"/2.5"	14"	20"
12219	C/C	3"	14"	20"
12225	C/O	2.25"	14"	20"
12226	C/O	2.5"	14"	20"
12229	C/O	3"	14"	20"
12255	C/O	2.25"	18"	24"
12259	C/O	3"	18"	24"
12268	C/D	2.5"	18"	24"
12286	C/O	2.5"	24"	30"
12288	C/D	3"/2.5"	18"	24"
12289	C/O	3"	24"	30"

Part#	Config.	In/Out	Body Length	Overall
11224	C/O	2"	14"	20"
11225	C/O	2.25"	14"	20"
11226	C/O	2.5"	14"	20"
11229	C/O	3"	14"	20"
11235	O/O	2.25"	14"	20"
11236	O/O	2.5"	14"	20"
11256	C/O	2.5"	18"	24"
11365	C/O	2.25"	11"	17"
11366	C/O	2.5"	11"	17"
11385	D/D	2.25"	14"	20"
11386	D/D	2.25"	14"	20"

**4"x9" Oval 409 Satin Stainless
Straight Through Performance
Muffler**



**4"x9" Oval 409 Satin
Stainless XL
Multi-Chamber
Performance Muffler**



Part#	Config.	In/Out	Body Length	Overall
13215	C/O	2.25"	14"	20"
13278	C/D	3"/2.25"	14"	20"

**5"x8" Oval Center/Center
Polished 409 Stainless
Performance Muffler With
Tip**



Part#	Config.	In/Out	Body Length	Overall
14827	C/C	2.25"	14"	23.125"

**5"x11" Oval 409
Satin Stainless
Straight Through
Performance
Muffler**



Part#	Config.	In/Out	Body Length	Overall
12589	C/O	3"	22"	28"
12909	C/O	3.5"	22"	28"

**4" Round Center/
Center 409 Satin
Stainless Straight
Through
Performance Muffler**



Part#	Config.	In/Out	Body Length	Overall
10415	C/C	2.25"	14"	20"
10416	C/C	2.5"	14"	20"
14419 Polished	C/C	3"	14"	20"

**3.5"x7" Oval Offset/
Offset 409 Satin
Stainless
Straight Through
Performance Muffler**



Part#	Config.	In/Out	Body Length	Overall
11132	O/O	2"/2.25"	11"	17"

FREE SHIPPING ON ALL SPECIAL ORDERS AND OUT OF STOCK ITEMS.



Exhaust TIPS

T-304 Stainless Steel Tips Installed By Professionals.
MagnaFlow's Polished Stainless Steel tips will last 5 times longer than chrome tips. These super tough tips will continue to shine for years to come with a lifetime warranty against defects.

Round Single Wall 15° Slash Cut



Diameter	Length	I.D. Inlet	Part#
3in.	18in.	2.5in.	35102
3.5in.	12in.	2.5in.	35205
3.5in.	12in.	3in.	35104
3.5in.	18in.	2.5in.	35105
4in.	18in.	2.5in.	35108
4in.	22in.	2.5in.	35109

Round Single Wall 45° Slash Cut



Diameter	Length	I.D. Inlet	Part#
3in.	18in.	2.25in.	35140
3in.	18in.	2.5in.	35138
3.5in.	18in.	2.25in.	35216
3.5in.	18in.	2.5in.	35143
3.5in.	22in.	2.25in.	35144
4in.	18in.	2.5in.	35146

Oval Single Wall Rolled Edge Angle Cut



Diameter	Length	I.D. Inlet	Part#
2.5in.x3.2in.	7.5in.	2.25in.	35129

Round Double Wall Slash Cut



Diameter	Length	I.D. Inlet	Part#
4in.	7in.	2.25in.	35121

Round Single Wall 15° Rolled Edge Angle Cut



Diameter	Length	I.D. Inlet	Part#
3in.	12in.	2.5in.	35204
3in.	18in.	2.5in.	35111
3.5in.	12in.	3in.	35113
3.5in.	18in.	2.25in.	35217
3.5in.	18in.	2.5in.	35114
4in.	12in.	3in.	35116
5in.	13in.	4in.	35120

Round Single Wall Rolled Edge Angle Cut



Diameter	Length	I.D. Inlet	Part#
3in.	7in.	2.25in.	35131
4in.	5in.	2.5in.	35136

Round Double Wall Straight Cut



Diameter	Length	I.D. Inlet	Part#
3.5in	4.5in	2.25in	35125

Round Double Wall Angle Cut (Sold As Pair)



Diameter	Length	I.D. Inlet	Part#
3in	9.75in	2.25in	35229



Smooth Transitions

Stamped Y-Pipe and Tru-X Pipe transitions are great for single/dual, dual/dual and balance tube applications. MagnaFlow's stainless steel Tru-X crossover pipe represents a significant leap forward in technology over traditional H-pipes. The more gentle radius allows for better exhaust gas scavenging, noise cancellation and better balance between cylinder banks. The result is a significant increase in power and torque but a reduction in db sound levels... the best of both worlds.

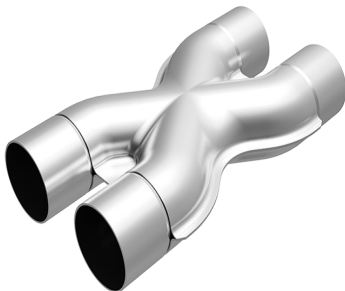

TYPE	INLET I.D.	CEN-TER CORE	PIPE LENGT H	PART#
Tru-X Pipe	2.5"	2.5" x 4"	12"	10791

TYPE	INLET DIAM-ETER	OUT-LET DIAM-ETER	PIPE LENGT H	PART#
T-Pipe	2.5" Dual	2.5" Single	8"	10734

TYPE	INLET DIAM-ETER	OUT-LET DIAM-ETER	PIPE LENGT H	PART#
Y-Pipe	2.25" Dual	2.5" Single	10"	10758
Y-Pipe	2.5" Dual	2.5" Single	10"	10768

FREE SHIPPING ON ALL SPECIAL ORDERS AND OUT OF STOCK ITEMS.



UNIVERSAL CONVERTERS

MANY MORE AVAILABLE

409 Stainless Steel Bodies



Oval No Oxygen Sensor Location	
12" Body L, 16" OAL, 5.625" Body W	
In/Out	OEM Grade Federal/EPA Compliant
2.25"	51005
2.5"	51006
3"	51009



Round No Oxygen Sensor Location			
9" Body L, 13" OAL, 4.25" Body W			
In/Out	OEM Grade Federal/EPA Compliant	Standard Grade Federal/EPA Compliant	HM Grade Federal/EPA Compliant
2"	51204	53004	
2.25"	51205		99205HM
2.5"	51206		99206HM



Round Post Converter Oxygen Sensor Location		
9" Body L, 13" OAL, 4.5" Body W		
In/Out	OEM Grade Federal/EPA Compliant	HM Grade Federal/EPA Compliant
2"	51234	99234HM
2.25"		99235HM
2.5"		99236HM



Round Post Converter Oxygen Sensor Location 51304 is Designed to fit the 2008-2010 Chevrolet Cobalt, 2008-2011 Chevrolet HHR, and additional vehicles. **51306** is Designed to fit the 2000-2011 Chevrolet Impala, 2000-2005 Buick LeSabre, and additional vehicles. **99305HM** is Designed to fit the 1997-2003 Chevrolet Malibu, 2006-2009 Hyundai Sonata, and additional vehicles.

11" Body L, 15" OAL, 4.25" Body W		
In/Out	OEM Grade Federal/EPA Compliant	HM Grade Federal/EPA Compliant
2"	51304	
2.25"		99305HM
2.5"	51306	99306HM



Round Midbed Oxygen Sensor Location		
11" Body L, 15" OAL, 4.25" Body W		
In/Out	OEM Grade Federal/EPA Compliant	HM Grade Federal/EPA Compliant
2"		99354HM
2.25"		99355HM
2.5"	51356	99356HM



Round Post Converter Oxygen Sensor Location	
11" Body L, 15" OAL, 4.25" Body W	
In/Out	OEM Grade Federal/EPA Compliant
2"	52324
2.25"	52325
2.5"	52326



Round Spun No Oxygen Sensor Location	
8" Body L, 8" OAL, 4" Body W	
In/Out	Standard Grade Federal/EPA Compliant
3"	59959



Round Spun No Oxygen Sensor Location	
12" Body L, 12" OAL, 6" Body W	
In/Out	HM Grade Federal/EPA Compliant
4"	60111



Round Spun Dual Oxygen Sensor Locations	
11.125" Body L, 15.125" OAL, 5" Body W	
In/Out	Standard Grade Federal/EPA Compliant
2.25"	79315
2.5"	79316



Oval Post Converter Oxygen Sensor Location	
12" Body L, 16" OAL, 5.5" Body W	
In/Out	Standard Grade Federal/EPA Compliant
2.5"	94036

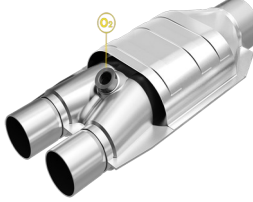

Oval Post Converter Oxygen Sensor Location	
12" Body L, 16" OAL, 6.375" Body W	
In/Out	Standard Grade Federal/EPA Compliant
2.5"/2"	94037













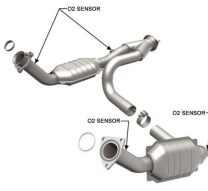



Oval No Oxygen Sensor Location	
15.5" Body L, 19.5" OAL, 6.5" Body W	
In/Out	Standard Grade Federal/EPA Compliant
3"	95509

FREE SHIPPING ON ALL SPECIAL ORDERS AND OUT OF STOCK ITEMS.

MAGNAFLOW

DIRECT-FIT CONVERTERS
MANY MORE AVAILABLE

409 Stainless Steel Bodies

 <p>55300 Fits: 94-96 Ford E-250 Econoline, 94-96 E-350 Econoline, 94-97 F-250 & F-250 Super Duty Pickup, 94-97 F-350 & F-350 Super Duty Pickup, 94-97 F-450 Super Duty Pickup, 94-97 F-53 Stripped Chassis/Camper</p>	 <p>93419 Fits: 02-06 Cadillac Escalade, 02-06 Chevy Avalanche, 99-07 Silverado 1500, 99-01 Silverado 2500, 00-06 Suburban, 00-06 Tahoe, 99-07 GMC Sierra 1500, 99-00 Sierra 2500, 00-06 Yukon, 00-06 Yukon XL</p>	 <p>51260 Fits: 07-17 Jeep Compass, Patriot, 07-08 Dodge Caliber 2.4L</p>
 <p>49225 Fits: 06-09 Chevy Impala, Monte Carlo, 08-09 Buick LaCrosse, 05-08 Pontiac Grand Prix 5.3L</p>	 <p>49445 Fits: 07-17 GMC Acadia, 09-17 Chevy Traverse, 08-17 Buick Enclave, 07-10 Saturn Outlook 3.6L</p>	 <p>49446 Fits: 07-17 GMC Acadia, 09-17 Chevy Traverse, 08-17 Buick Enclave, 07-10 Saturn Outlook 3.6L</p>
 <p>49849 Fits: 07-09 Mitsubishi Raider, 07-09 Dodge Dakota 3.7L</p>	 <p>51448 Fits: 06-11 Legacy, Outback, Impreza, Forester, 06 Saab 9-2X 2.5L</p>	 <p>52092 Fits: 11-17 Chevy Cruze, Sonic, Trax, 13-17 Buick Encore 1.4L</p>
 <p>52227 Fits: 11-18 Dodge Avenger, Grand Caravan, Journey, 11-16 Chrysler 200, Town & Country, 12-15 Ram C/V, 11-14 Volkswagen Routan 3.6L</p>	 <p>52305 Fits: 06-12 Subaru Forester, Impreza, Legacy, Outback, 06 Saab 9-2X 2.5L</p>	 <p>93200 Fits: 03-08 Toyota Corolla, Matrix, 03-08 Pontiac Vibe 1.8L</p>
 <p>93235 Fits: 99-05 Subaru Forester, Impreza, Outback, 05 Saab 9-2X 2.2L, 2.5L</p>	 <p>93257 Fits: 07-17 Nissan Altima 2.5L</p>	 <p>5531060 Fits: 08-10 Pontiac G6, 08-10 Chevy Malibu, 07-09 Saturn Aura 2.4L</p>

FREE SHIPPING ON ALL SPECIAL ORDERS AND OUT OF STOCK ITEMS.

MANDREL PREBENT

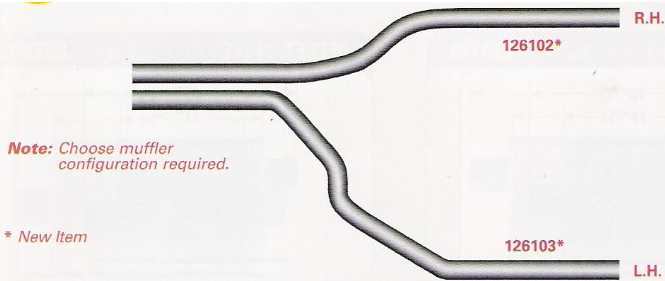

87-02 CHEV./GMC TRUCK C/K SERIES, DUAL CONVERSION
 87-04 DODGE TRUCK 1500/2500, DUAL CONVERSION
 87-02 FORD TRUCK F-SERIES, DUAL CONVERSION

14 Gauge Mandrel Tail Pipes			
Right Side #	Left Side #	Diameter	Material
26102S	26103S	2.25"	Stainless Steel
H25409	H25410	2.5"	Stainless Steel
H25411	H25412	3"	Stainless Steel

14/16 Gauge Stainless Steel Tubing



STAINLESS STEEL STRAIGHT TUBING					
PART #	TUBE DIA.	GAUGE	LENGTH	MATERIAL	GRADE
S41341200	1.75"	14	10'	Stainless Steel	T409
S42001200	2"	14	10'	Stainless Steel	T409
S42251200	2.25"	14	10'	Stainless Steel	T409
S42501200	2.50"	14	10'	Stainless Steel	T409
S43001200	3"	14	10'	Stainless Steel	T409
4001016S	4"	16	10'	Stainless	T409



Application		
01-06 Chevy/GMC 8 Cyl. 1500, 2500, 3500 HD Series; 6.0L, 8.1L Gas Engines		
88-99 Chevy/GMC 8 Cyl. Full Size, Light Duty Trucks; 5.7L exc. 88-90 Suburban		
88-01 Dodge 8 Cyl. Full Size, Light Duty Trucks		
Mandrel Bent		
Part#	Dia.	Material
X6007SS	3"	Stainless Steel



Part# FRLOAAS02S
 Stainless Steel Overaxle Pipe w/Air-Ride Suspension For 2002-Up Freightliner Mercedes 4 & 6 cyl. Engine



Stainless Steel Smooth Transitions
 Use Mandrel-Bent Smooth Transitions for custom system fabrication with no reduction in the bends.

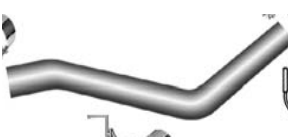

Application
94-02 6 Cyl. Ram 2500/3500; 5.9L Cummins Turbo Diesel Engine, All Wheel Bases

TYPE	INLET DIAMETER	C-LINE RADIUS	LENGTH TO BEND	PART#
L-180	2.5"	4"	14"	10716M
L-180	3"	5"	14"	10719M

Mandrel Bent		
Part#	Dia.	Material
54997MS	4"	Stainless Steel

FREE SHIPPING ON ALL SPECIAL ORDERS AND OUT OF STOCK ITEMS.

FLEX PIPES



304 Stainless Braid & Bellows

PART #	DESCRIPTION
FT13404BI	1 3/4" X 4" FLEX BLANK INTERBRAIDED ENDS
FT13404NI	1 3/4" X 4" DOUBLE FLEX 1 3/4" ENDS
FT13406BI	1 3/4" X 6" FLEX BLANK INTERBRAIDED ENDS
FT13406NI	1 3/4" X 6" DOUBLE FLEX 1 3/4" ENDS
FT13408BI	1 3/4" X 8" FLEX BLANK INTERBRAIDED ENDS
FT13408NI	1 3/4" X 8" DOUBLE FLEX 1 3/4" ENDS
FT13410BI	1 3/4" X 10" FLEX BLANK INTERBRAIDED ENDS
FT13410NI	1 3/4" X 10" DOUBLE FLEX 1 3/4" ENDS
FT20004BI	2" X 4" FLEX BLANK INTERBRAIDED ENDS
FT20004NI	2" X 4" DOUBLE FLEX 2" ENDS
FT20006BI	2" X 6" FLEX BLANK INTERBRAIDED ENDS
FT20006NI	2" X 6" DOUBLE FLEX 2" ENDS
FT20008BI	2" X 8" FLEX BLANK INTERBRAIDED ENDS
FT20008NI	2" X 8" DOUBLE FLEX 2" ENDS
FT20010BI	2" X 10" FLEX BLANK INTERBRAIDED ENDS
FT20010NI	2" X 10" DOUBLE FLEX 2" ENDS

PART #	DESCRIPTION
FT22504BI	2 1/4" X 4" FLEX BLANK INTERBRAIDED ENDS
FT22504NI	2 1/4" X 4" DOUBLE FLEX 2 1/4" ENDS
FT22506BI	2 1/4" X 6" FLEX BLANK INTERBRAIDED ENDS
FT22506NI	2 1/4" X 6" DOUBLE FLEX 2 1/4" ENDS
FT22508BI	2 1/4" X 8" FLEX BLANK INTERBRAIDED ENDS
FT22508NI	2 1/4" X 8" DOUBLE FLEX 2 1/4" ENDS
FT22510BI	2 1/4" X 10" FLEX BLANK INTERBRAIDED ENDS
FT22510NI	2 1/4" X 10" DOUBLE FLEX 2 1/4" ENDS
FT25004BI	2 1/2" X 4" FLEX BLANK INTERBRAIDED ENDS
FT25004NI	2 1/2" X 4" DOUBLE FLEX 2 1/2" ENDS
FT25006BI	2 1/2" X 6" FLEX BLANK INTERBRAIDED ENDS
FT25006NI	2 1/2" X 6" DOUBLE FLEX 2 1/2" ENDS
FT25008BI	2 1/2" X 8" FLEX BLANK INTERBRAIDED ENDS
FT25008NI	2 1/2" X 8" DOUBLE FLEX 2 1/2" ENDS
FT25010BI	2 1/2" X 10" FLEX BLANK INTERBRAIDED ENDS
FT30006BI	3" X 6" FLEX BLANK INTERBRAIDED ENDS
FT30006NI	3" X 6" DOUBLE FLEX 3" ENDS



Hangers, Brackets, Wires, & Spherical Joints

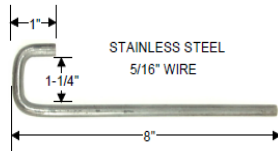

Part# BR92216-010

409 Stainless Steel Spherical Joint System / Top Numbers

SPHERICAL JOINT SYSTEM

Part No.	Description
SJS2	spring-loaded ball joint for use in connecting exhaust systems



- Competitive Price- Lower cost alternative to flex couplings.
- Self Supporting-Can support weight of exhaust systems in horizontal or vertical direction. Eliminates extra support hangers.
- Torsional Degree of Freedom-Capable of accommodating relative twist between upstream and downstream portions of the joint.
- Stable, Consistent Performance-Unlike flex exhaust decouplers, whose damping and support members change over time, this system displays consistent dynamic performance.

for 1-3/4" & 2" pipe

US Patent 5,683,119



**Part# 63S O2
Sensor Boss
M18 x 1.5
(Stainless Steel)**



FREE SHIPPING ON ALL SPECIAL ORDERS AND OUT OF STOCK ITEMS.

**Performance
Products**

**MORE
PRODUCTS
AVAILABLE!**

**409 Stainless
Steel OE Whisper
Quiet Direct Fit
Mufflers**



Part# OE71S O/O / 1 5/8" In. / 1 3/4" Out Spout / 14" Body Length / 24" Overall / 4 1/4" x 8 3/4" Body Size
Fits: 82-85 Honda Accord 1.8L, 83-87 Prelude 1.8L

Part# OE257S C/O / 2 1/4" In. / 2" Out / 23 1/4" Body Length / 30" Overall / 4 1/16" x 10 1/2" Body Size Fits:
00 Chrysler Grand Voyager 3.0L, 3.3L, 96-07 Town & Country 3.3L, 3.8L, 00-03 Voyager 3.0L, 3.3L, 96-03 Dodge Caravan 3.0L, 3.3L, 3.8L, 96-05 Grand Caravan 3.0L, 3.3L, 3.8L, 96-00 Plymouth Grand Voyager 3.0L, 3.3L, 3.8L, 96-00 Voyager 3.0L, 3.3L, 3.8L

**Stainless Steel
Whisper Quiet
Universal
Mufflers**



<u>Part#</u>	<u>Inlet/Outlet</u>	<u>Body Length</u>	<u>Body Size</u>
STL20S	2" - 2" O/C	14"	4" x 9"
STL22S	2" - 2" O/C	17"	4" x 9"
STL28S	2 1/4" - 2 1/4" O/C	21"	5" x 11"
STL30S	2 1/2" - 2 1/2" O/C	21"	5" x 11"
STL2268	2 1/2" - 2 1/2" D/C	18"	5" x 11"



STAINLESS STEEL MANDREL 45° BEND
2 1/4" - PART# S22545
2 1/2" - PART# S25045
3" - PART# S30045



STAINLESS STEEL MANDREL 90° BEND
2 1/4" - PART# S22590
2 1/2" - PART# S25090
3" - PART# S30090



**Performance Stainless Steel Whisper
Quiet Muffler Part# OE60**
2 1/4"x2 1/4"x2 1/4", 18" Body,
24" OAL



**Performance Stainless Steel
Whisper Quiet Muffler
Part# OE80 2 1/4"x2 1/4",
18" Body, 24" OAL**



Stainless Steel Tips

409 Hi Polished Stainless Steel Tips



Part # 00731
4" Round
9" Long
2 1/4" Inlet



00831
6" X 3"
Rolled Slant Oval
9" Long



Part # 00733
3" Round Double Wall
7" Long
2 1/4" Inlet



Part # 00734
4" x 3 1/2" Square
7" Long
2 1/4" Inlet



Part # 00735
4" Round
9" Long
2 1/4" Inlet



Part # 00736
4 1/2" Round
9" Long
2 1/4" Inlet



Part # 00822
Rolled Pencil Tip
2 1/8" x 9"
2 1/4" Inlet



Part # 00745
2 1/2" Rolled Pencil
10" Long
2 1/4" Inlet



Part # 00747
5 1/2" x 3" Rolled
Slant Oval
9 1/2" Long
2 1/4" Inlet



Part # 00747-212
5 1/2" x 3" Rolled Slant
Oval
9 1/2" Long
2 1/2" Inlet



Part # 00811
6 3/4" x 3 3/4" Moon
Shape Slant Rolled
(Left)
11 1/2" Long
2 1/4" Inlet



Part # 00748
7 3/4" x 2" Camaro
10" Long 2 1/4" Inlet
Part # 00749
7 3/4" x 2" Camaro
10" Long 2 1/2" Inlet



Part # 00808
5 1/2" x 3" Oval
6 1/2" Long
2 1/4" Inlet



Part # 00755
3 3/4" Dual Turn Up
12" Long
2 1/4" Inlet



Part # 00756
3 1/2" Dual Rolled Slant
12" Long
2 1/4" Inlet



Part # 00759
3 1/2" Dual Slant
Double Wall
14" Long
3" Inlet



Part # 00818
3" x 9" Rolled
3" Inlet



409

Hi Polished Stainless Steel Mufflers

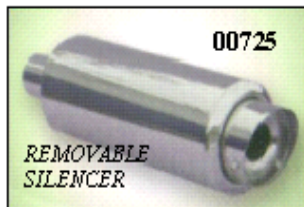



409 Stainless Steel Tips

Hi Polished Stainless Steel Diesel Tips

 Part # 00764 5" Rolled Angle 15" Long 4" Inlet	 Part # 00765 6" Rolled Angle 15" Long 5" Inlet	 Part # 00815 5" Double Wall Angle Cut 12" Long 4" Bolt-On Inlet
---	---	---

Super Duty Vented Diesel Tips

Part # 00768
 5" Straight Cut
 16" Long
 4" Inlet



Hi Polished "Black Stainless" Tips

45° Angle Cut

Part # 00738S 3" x 16" 2 1/4" Inlet	Part # 00739S 3 1/2" x 18" 2 1/4" Inlet
Part # 00740S 3 1/2" x 22" 2 1/4" Inlet	Part # 00742S 4" x 18" 2 1/4" Inlet



30° Rolled Angle

Part # 00738RS
 3" x 16"
 2 1/4" Inlet

Part # 00739RS
 3 1/2" x 18"
 2 1/4" Inlet



Part # 00742RS
 4" x 18"
 2 1/4" Inlet

Part # 00747S
 5 1/2" x 3" Rolled Slant Oval
 9 1/2" Long
 2 1/4" Inlet

Part # 00756S
 3 1/2" Dual Rolled Slant
 12" Long
 2 1/4" Inlet

Hi Polished 45° Angle Cut Stainless Steel Truck Tips



Part # 00744 3" x 12" 2 1/4" Inlet	Part # 00738 3" x 16" 2 1/4" Inlet	Part # 00753 3 1/2" x 12" 2 1/4" Inlet
Part # 00753-212 3 1/2" x 12" 2 1/2" Inlet	Part # 00829 3 1/2" x 16" 2 1/4" Inlet	Part # 00739 3 1/2" x 18" 2 1/4" Inlet
Part # 00739-212 3 1/2" x 18" 2 1/2" Inlet	Part # 00740 3 1/2" x 22" 2 1/4" Inlet	
Part # 00754 4" x 12" 2 1/4" Inlet	Part # 00742 4" x 18" 2 1/4" Inlet	
	Part # 00743 4" x 22" 2 1/4" Inlet	

Hi Polished 30° Rolled Angle Stainless Steel Truck Tips



Part# 00742R-212 4" X 18" 2 1/2" Inlet	Part # 00738R 3" x 16" 2 1/4" Inlet	Part# 00754R 4" X 12" 2 1/4" Inlet
Part # 00753R 3 1/2" x 12" 2 1/4" Inlet	Part # 00829R 3 1/2" x 16" 2 1/4" Inlet	Part # 00739R 3 1/2" x 18" 2 1/4" Inlet
Part # 00739R-212 3 1/2" x 18" 2 1/2" Inlet	Part # 00740R 3 1/2" x 22" 2 1/4" Inlet	Part # 00742R 4" x 18" 2 1/4" Inlet
Part# 00753R-212 3 1/2" X 12" 2 1/2" Inlet	Part # 00743R 4" x 22" 2 1/4" Inlet	



New GENERATION SPUN FORMED CONVERTER
 One Piece Polished Stainless Steel • Zero Leakage – Fits Tight Applications
409

2 & 3 Way - 5.9L/6,000 Lbs. • Angled Inlet or Outlet
 4" Round x 8" Long • OBDII Compliant (Exc. Calif.)

Part #	Inlet/Outlet
402200	2"
402225	2 1/4"



2 & 3 Way - 5.9L/6,000 Lbs.
 4" Round x 11" Long
 OBDII Compliant (Exc. Calif.)



Part#	Inlet/Outlet
410175	1 3/4"
410200	2"
410225	2 1/4"
410250	2 1/2"
410250S	2 1/2" / 8" Long
410300	3"
410300S	3" / 8" Long

300 Cell - Hi Flow 2 & 3 Way - 5.9L/6,000 Lbs.
 Metallic Substrate • 4" Round x 11" Long
 OBDII Compliant (Exc. Calif.)

Part #	Inlet/Outlet
415225	2 1/4"
415250	2 1/2"
415300	3"



2 & 3 Way • With O2 Sensor Port - 5.9/6,000 Lbs.
 4" Round x 11" Long
 OBDII Compliant (Exc. Calif.)

Part #	Inlet/Outlet
425225	2 1/4"



HEAVY LOAD

THE "SPUN SOLUTION" CONVERTER
 Heavy Duty • 5.9L/6,000 Lbs.
 4" Round x 13" Long
 OBDII Compliant (Exc. Calif.)

Part #	Inlet/Outlet
435200	2"
435225	2 1/4"
435250	2 1/2"
435300	3"

* Designed for problem engines
 i.e. GM 3.1L, 3.4L, 3.8L



HEAVY LOAD

THE "SPUN SOLUTION" CONVERTER
 With O2 Sensor Port
 Heavy Duty • 5.9L/6,000 Lbs.
 4" Round x 13" Long
 OBDII Compliant (Exc. Calif.)

Part #	Inlet/Outlet
445200	2"
445250	2 1/2"



HEAVY LOAD

Honda
 With Angled O2 Sensor Port
 5.9L/6,000 Lbs.
 4" Round x 13" Long
 OBDII Compliant (Exc. Calif.)

Part #	Inlet/Outlet
455200	2"
455225	2 1/4"
455250	2 1/2"



SPUN CATALYTIC CONVERTER
 UNIVERSAL

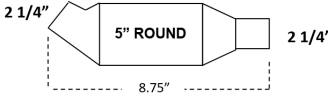

2 1/4" 5" ROUND 2 1/4"
 8.75"

5.9L / 6,000 LBS
 OBDII COMPLIANT (Exc. CALIF.)

Part #	In/Out
502225	2 1/4"
502250	2 1/2"

"SPUN SOLUTION" HD
 UNIVERSAL CATALYTIC CONVERTER
 WITH CENTER O2 PORT

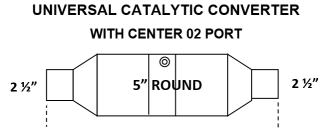

2 1/2" 5" ROUND 2 1/2"
 15 1/4"
 6.2 L / 9,000 LBS
 OBDII COMPLIANT (Exc. CA)

Part #	In/Out
555225	2 1/4"
555250	2 1/2"
555300	3"

OBDII - 5.9L/6,000 Lbs. • 16" Long
 OBDII Compliant (Exc. Calif.)

Part #	Inlet/Outlet
590005	2 1/4"
590006	2 1/2"
590007	3"



TRUCK DIESEL UNIVERSAL CONVERTER
 6" Round x 12" Long

Part #	Inlet/Outlet
810312	3 1/2"
810400	4"

Accessories

Part #	In/Out
63	O2 Sensor Nut 1/2"xM 18/1.5
63-45	O2 Sensor Nut/Angled 1/2"xM 18/1.5
107	O2 Sensor Port Plug 1/2" x M 18/1.5